

## VENDE RETNING PÅ GALLI SLANGERULLER MED 1 FJEDER

### Punkt 1. Cover Siden:

1. Afmonter plastic cover (NR.19).
2. Afmonter de M6 møtrikker (nr.4) som holder den udvendige plade (nr.17), og tag pladen af.
3. Tag halvmåne nr. 16 af.
4. Union nr. 12 er monteret med plast propper i den ene side og stål propper i den anden, disse byttes.
5. Vend Halvmånen nr. 16 180° og monter den igen.
6. Monter pladen nr. 17 og plastic coveret nr. 19 igen.

### Punkt 2. Holderens side:

1. Afmonter Holderen (nr.2).
2. Fjern M6 møtrikkerne (nr.4) der holder pladen nr. 5.
3. Afmonter forsigtig fjeder kittet (nr.5+6+8).
4. Vend fjeder kittet så mærket "attention spring under pressure" er opad.
5. Afmonter skruen M6x14 og tag pladen nr.8 væk.
6. Tag forsigtig fjederen (nr.6) op af pladen nr.5 "VÆR FORSIGTIG".
7. Vend fjederen om. (nr.6)
8. Monter det hele i modsatte rækkefølge. (fra punkt. 5 til 1)

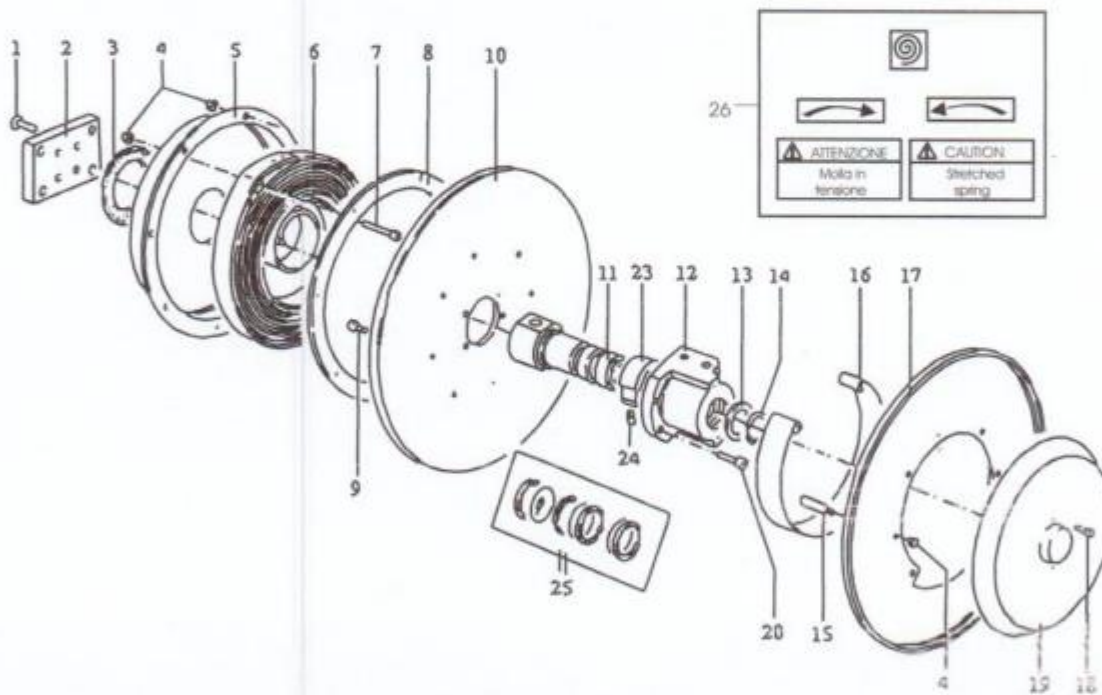

## VENDE RETNING PÅ GALLI SLANGERULLER MED 2 FJEDER

Fra Holderens side:

1. Afmonter Holderen (nr.21).
2. Afmonter Fjeder Kit 1 nr. 12+13+16.

Fra modsatte side:

3. Afmonter Fjeder Kit 2 nr. 30
4. Vend Fjedrene i begge kits "VÆR FORSIGTIG"
5. Monter Fjeder Kit 1 på diskene.
6. Monter Fjeder Kit 2 på diskene

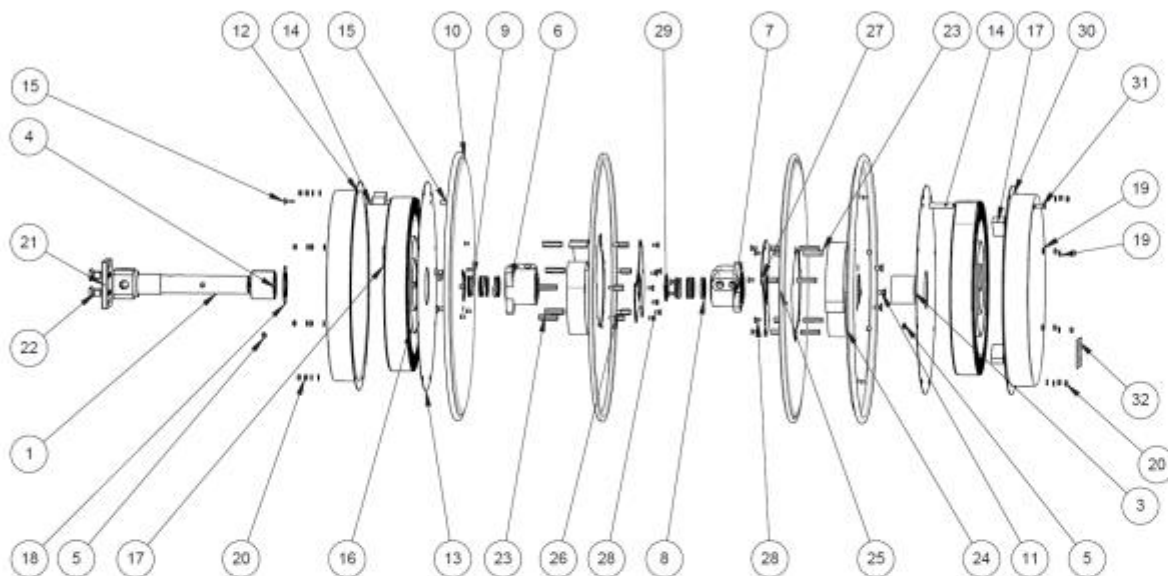

IN ENGLISH

### Turning Direction on GALLI Hose reels with 1 spring

Please follow this instructions:

#### From cover side:

- 1) Take away the plastic cover (nr.18)
- 2) Unscrew the Nr.4 nuts M6 which fix the external disc (nr.17)
- 3) Take off the fillet (nr.16)
- 4) Dismounting the 2 hexagonal 3/8" plugs which you can find on the body and insert onto the other 2 holes.  
=> **when the body is reversible, you can find 2 holes on the left side and two on the right side. If so, just go ahead, if no, you need some spare parts....**
- 5) Turn the fillet (nr.16) on the opposite side (180°) and remounting it
- 6) Remounting the external disc (nr.17)

#### From bracket side:

- 1) Unscrew the bracket (nr.2)
- 2) Unscrew Nr.4 M6 self - blocking screw which take together the spring (nr.5)
- 3) Take off **with attention** the spring kit (nr.5+6+8).
- 4) Turn the spring kit on the opposite side (with the label "attention spring under pressure" on the top)
- 5) Unscrew the screws M6x14 and take away the spring cover disc (nr.8)
- 6) Take away the spring: **please pay attention during this operation (nr.6)**
- 7) Turn the spring on the opposite side (nr.6)
- 8) Remounting the hose reel

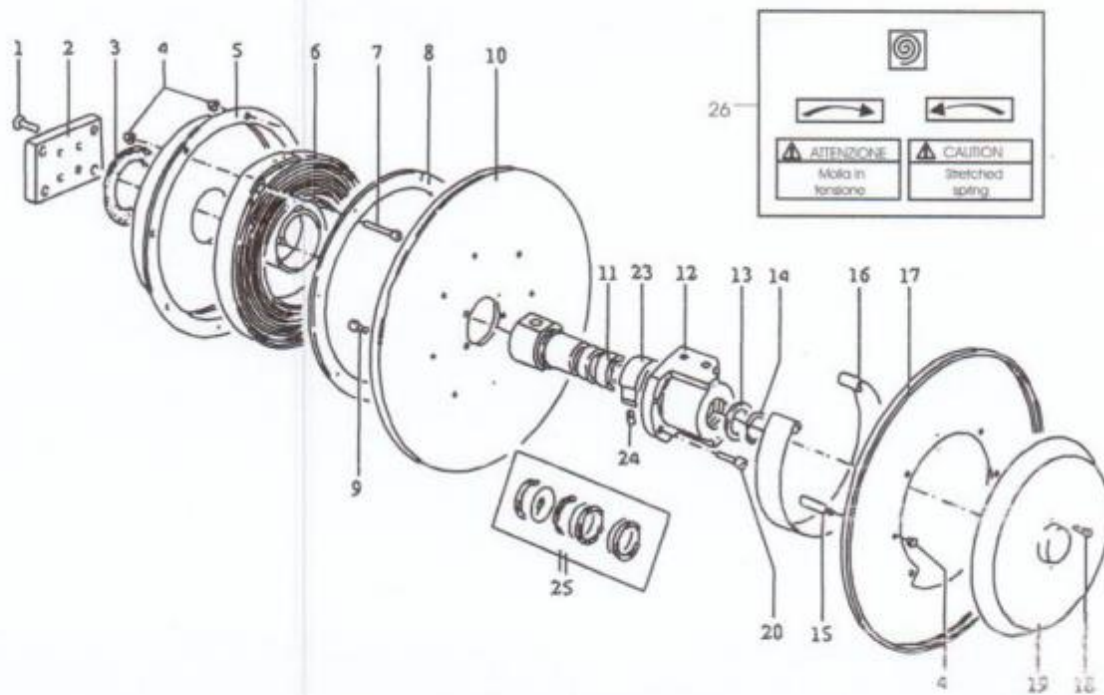

### Turning Direction on GALLI Hose reels with 2 spring

1. Take away the first spring kit + it's discs
2. Than the 2<sup>nd</sup> spring kit and also it's discs,
3. Change winding direction (open with attention the spring kit and turn the spring on the opposite side)
4. Than first you should reassemble starting with the 1<sup>st</sup> spring kit with discs
5. Than the 2<sup>nd</sup> with it's discs

